

# GNSS on the Go

## Sensitivity and Performance in Receiver Design

MALCOLM LOMER, STEFAN FULGA, AND PETER GAMMEL  
SIGE SEMICONDUCTOR

As GNSS positioning moves into ever more mobile and electromagnetically and operationally challenging environments, receiver designers must figure out how to make user equipment sensitive and robust enough to perform well while simultaneously minimizing cost and power requirements. This article covers such issues of receiver design as internal signal interference, integration with existing platform architecture, software-based designs, and common errors in design assumptions.

Copyright iStockphoto.com/Karina Tischlinger

Position tracking is no longer limited to fixed automotive applications or expensive handheld tracking systems. Consumer demand combined with recent innovations in GNSS technology is making position tracking a must-have feature in a wide range of cost-sensitive applications, including cellular handsets, personal navigation systems, and other consumer electronic devices.

Developing a GNSS position tracking subsystem for consumer electronic devices can appear to be a daunting challenge. Developers must not only keep down costs while maximizing performance and accuracy, they have to do so using RF technology with which they may have little experience.

Sensitivity is the key to accuracy of a GNSS receiver. The signals that a GNSS receiver tries to detect and process are

buried in noise; therefore, the task of maintaining signal integrity is a key challenge for many developers.

- This article describes how becoming familiar with a few key aspects of RF design can help developers avoid many of the seemingly arbitrary design decisions that can cause position tracking functionality to fail to achieve sufficient accuracy. It also highlights how developers can exploit software-based GNSS baseband architectures to reduce RF subsystem complexity while further increasing sensitivity and positioning accuracy.

### Overcoming Internal Interference

Their almost universal market penetration makes cellular handsets one of the most popular platforms onto which position tracking is being introduced.

However, the presence of a collocated GSM or other wireless transmitter, limited power budgets, and noise arising from tight physical constraints also make this application one of the most difficult architectures into which to integrate new functionality.

Consider that a typical GSM phone will transmit approximately +33 dBm at the relevant GSM frequency (~900 MHz) and +30 dBm at 1800 MHz or 1900 MHz. Because of the proximity of the GSM transmitter to the GNSS receiver, sufficient noise scatter may pass from the GSM band into the spectrum used by the GNSS to overwhelm weak satellite signals. By isolating the pick-up of the GSM signal by the GNSS receiver, developers can eliminate the direct noise contribution from GSM signals and hence maintain the sensitivity of the GNSS receiver.

But how can we achieve this goal?

**Step 1: Increase Linearity.** One potential problem area within the GNSS subsystem is the low noise amplifier (LNA) in the radio front-end. If the LNA does not have enough linearity, a strong cell signal will saturate the LNA, effectively blinding it from seeing lower-strength GNSS signals (see **Figure 1**). This causes *gain compression*, in which the gain of the amplifier is reduced to limit the GSM signal but at the same time reduces the GNSS signal (see **Figure 2**).

In this situation, the GNSS signal is attenuated to the point where it virtually disappears. To overcome gain compression, the LNA needs to have a high linearity, enabling the LNA to amplify low and high signals simultaneously without the GSM signal corrupting the GNSS signal.

Note that getting the GNSS signal past the LNA is simply the first step. The system still needs to avoid overloading subsequent stages such as the mixer.

Unfortunately, to increase linearity in a circuit, one must also increase the current. This creates a trade-off decision for battery-operated devices. Developers will need to reduce the gain so as to not overload the mixer in the next step in the signal chain.

Product designers face a clear choice in achieving the needed linearity, pursuing one or both of the following alternatives: reduce the gain of the LNA, which also reduces signal sensitivity and/or introduce a filter between the LNA and mixer, which increases the system's bill of materials (BoM). In effect, using a filter changes the power-versus-performance trade off into a cost-versus-performance decision.

**Step 2: Eliminate GSM interference.** A seemingly obvious approach to eliminating GSM interference is to subtract any transmitted signals from the received signal. This sort of feedback correction, however, is primarily theoretical and not yet cost-effective to implement in consumer electronics devices, especially in light of more practical alternatives.

For example, GSM employs a time-shared, frame-based mechanism. Even during its allotted time slots, a GSM

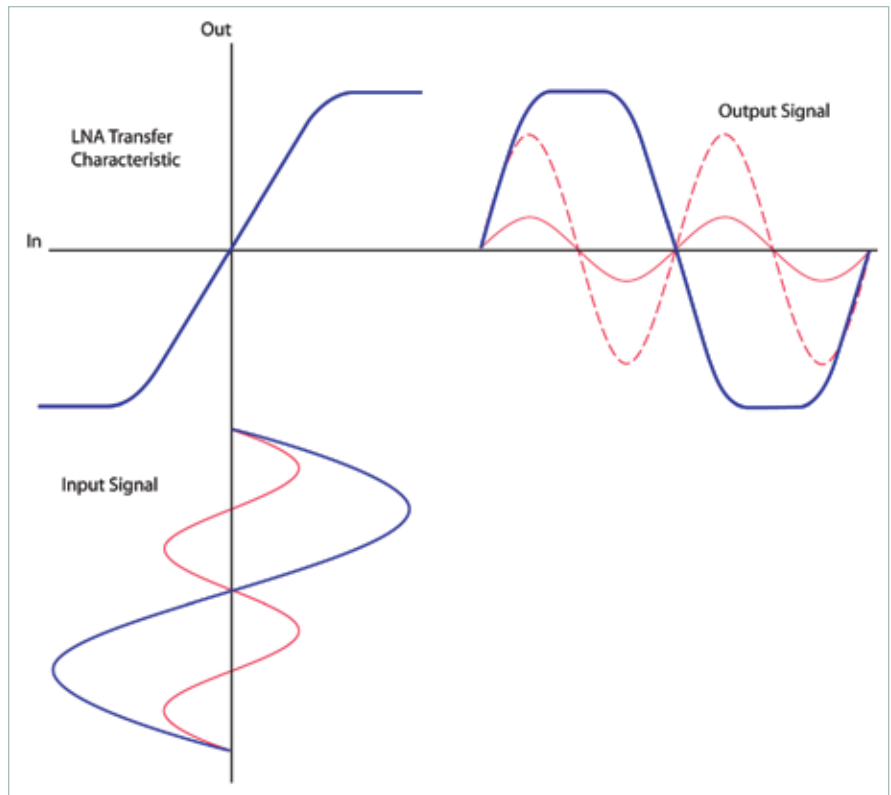

**FIGURE 1** The close proximity of a GNSS receiver to a GSM transmitter with a power of approximately +33 dBm introduces enough noise scatter into the GPS band to overwhelm weak satellite signals. In this diagram, we use continuous wave signals to illustrate this point. With a simultaneous large signal (blue line) and small signal (red line) input to the LNA, the large signal can be clipped by the LNA, as a result of excessive amplitude. This has the effect of reducing the gain of the LNA so that the small signal (red) output amplitude is not as high as it should be (red-dotted line).

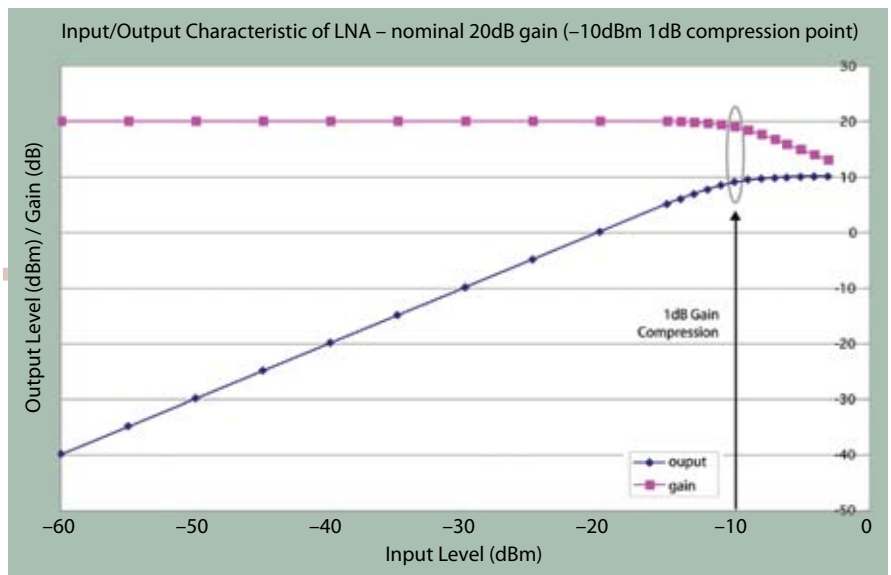
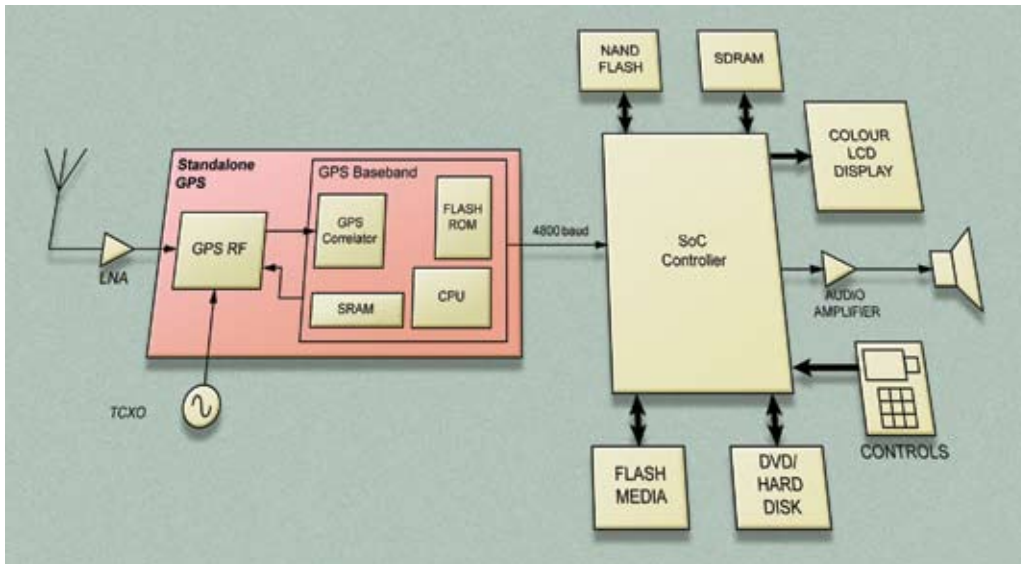

**FIGURE 2** Gain compression results from a large signal input to an amplifier, which, in turn, reduces the amplifier gain and the signal-level output of any small signals being simultaneously input.

device is receiving for more time than it is transmitting. As a result, a GSM cellular handset is actually transmitting on average only 12.5 percent of the time.

However, we can increase this trans-

mission rate by using GPRS data packets, if multiple time slots have been allocated. By synchronizing with the GSM supervisor, the GNSS subsystem can elect to receive at those times when no interfer-



**FIGURE 3** Hardware-based GPS receiver systems normally use a separate standalone GPS receiver connected to an application SoC controller.

ence is coming from the GSM transmitter. Moreover, the GNSS receiver can power down appropriately during GSM transmit slots.

Time-sharing, then, is an effective way to maintain position accuracy while conserving power after achieving initial signal lock and positioning. However, practically implementing the time-sharing approach faces a significant obstacle: with GPS, currently the most widely used system, the handset's GNSS receiver subsystem typically needs uninterrupted access to satellite signals for at least 30 seconds — the average time to first fix (TTFF) during which the receiver downloads the satellites' ephemeris (orbital) data.

**Step 3: Implement Assisted-GPS.** Faced with these technical constraints, for quite some time the cellular industry has been pursuing what is known as A-GPS (or assisted-GPS). With A-GPS, the GPS receiver downloads assistance data over a telemetry link (i.e., the standard cell phone connection to the cellular network) from a server that is able to provide up-to-date satellite orbital data. This information essentially tells the receiver which satellites are in view and where to “look” for them.

The A-GPS telemetry link does not supply all the information needed for position-fixing — access to multiple “live” GNSS signals is still required

— but it does reduce the “time to first fix” (TTFF) from approximately 30–40 seconds to less than 10 seconds in most situations. A-GPS also increases the possibility of using GPS technology inside buildings where satellite access is often seriously curtailed.

Because of its usefulness, A-GPS could be considered almost a mandatory feature of GSM handsets. From a cost standpoint, given the ready availability of a telemetry link, the A-GPS data decoding function is implemented entirely in software. Additionally, A-GPS significantly improves one of the key differentiating features of position tracking systems: TTFF.

From a product standpoint, of course, we need to recognize that A-GPS cannot simply be added to existing *hardware-based* GNSS subsystems. Because it is an integral part of acquiring first fix and maintaining signal lock, A-GPS functionality must be integrated within the baseband processor. However, systems already using *software-based* baseband processing technology are flexible enough to support migration to A-GPS.

### Software-Based Architectures

The usual method for providing GPS capability in a mobile device is to add a complete GPS receiver system in front of

the existing applications system on chip (SoC) controller (see **Figure 3**). This is often the easiest route because the GPS receiver function is encapsulated in a single add-on integrated circuit.

Some systems now use an applications SoC processor that incorporates a dedicated GPS correlator, which can reduce the RF system complexity and BoM. With this approach developers need only add an RF transceiver and antenna to existing devices (see **Figure 4**).

With software-based baseband architectures, designers can achieve the

same reduction in RF system complexity and a further BoM reduction by using a general-purpose SoC controller without any dedicated GPS correlators included (see **Figure 5**). The flexibility of a software-based implementation also enables developers to adjust processing and power-saving techniques to meet the specific cost, power, and performance specifications of each application.

Because a single hardware radio architecture can serve across a diverse range of applications, OEMs can achieve better economies of scale. Additionally, new algorithms that improve signal capture and processing can be implemented as they emerge, extending the viability of radio architectures while continuing to improve characteristics such as accuracy and tracking sensitivity.

For some applications, the flexible nature of software-based GNSS can also produce higher accuracy than hardware-only designs do.

Ultimately, both hardware- and software-based baseband architectures are well suited for a wide range of applications. For example, laptops and ultra mobile PCs (UMPCs) are excellent candidates for software-based baseband processing, given the availability of substantial processing resources and aggressive cost requirements. Moreover, the presence of large batteries mitigates any power consumption concerns. Software

GPS is also suitable for digital cameras in which space comes at a premium and cost is a primary design constraint.

Today's hardware-based GPS system is well suited for applications such as personal navigation devices (PNDs) and personal media players. In such devices, a hardware baseband can combine GPS processing with other system functions such as digital audio and video processing.

Although hardware-based processing clearly dominate in traditional handheld devices today, software-based GPS is expected to penetrate these applications during the coming years as available processing capacity increases and RF hardware costs continue to drop.

### Maintain Sensitivity in Existing Architectures

Developers might be tempted to assume that, even without careful consideration, they can maintain the sensitivity of the GNSS subsystem by sharing certain components with the existing architecture into which it is being introduced. This idea stems from three common misconceptions about processing resource loading, power isolation, and the feasibility of sharing a system oscillator.

**Processing Resource Loading.** Hardware-based GNSS modules still require application-level processing to convert position data from the module into position tracking information that users can access (i.e., displaying location on a map). Flexible software-based GNSS systems can readily employ such techniques as dead reckoning, reduced signal processing, and idle cycle capture can be employed to increase positioning accuracy while substantially reducing power consumption.

With either technology, some minimum load will be placed on the main application processor, a load that the system must be able to support under worst-case operating conditions, for example, when a handset is receiving a call or a personal media player is decoding a video stream.

**Power Considerations.** From a power perspective, given the low-level signals with which GNSS receivers must be able

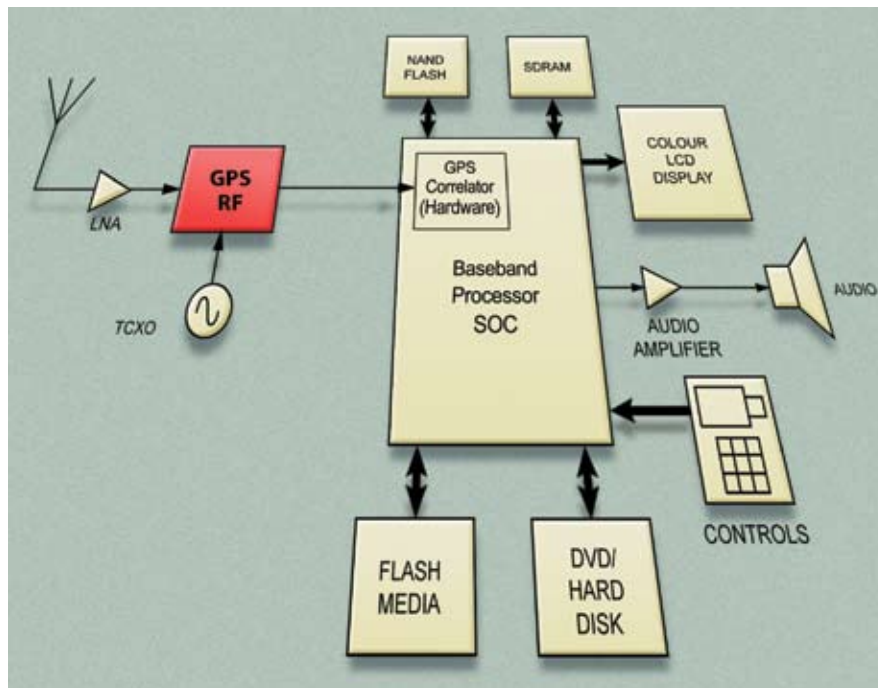

FIGURE 4 Some hardware-based GPS receivers use a dedicated GPS SoC baseband processor, which needs only an RF front end and antenna to realize a full GPS receiver.

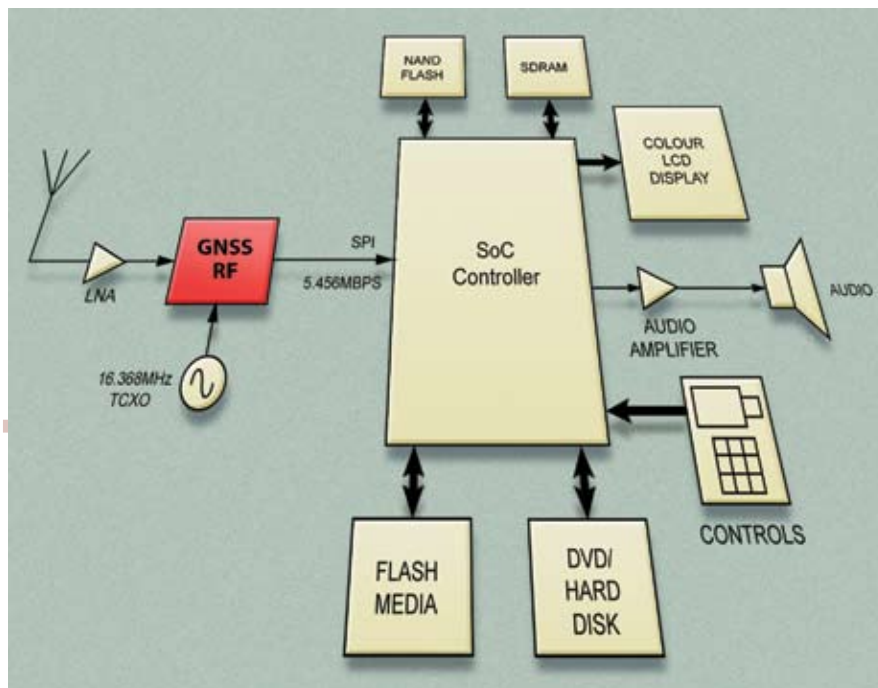

FIGURE 5 Software-based architectures use a general-purpose SoC controller, which needs only the addition of an RF front end and antenna to realize a full GPS Receiver.

to work, developers need to be careful when introducing position tracking to existing architectures. For example, the broadband power amplifier used in cellular handsets tends to lack frequency-selective filtering and can inject

unwanted noise at the GNSS receive frequency, thereby affecting GNSS receiver sensitivity.

The best solution is to place a resonance trap to eliminate any noise coming out of the power amplifier at GNSS

signal frequencies. As an alternative, or in conjunction with a resonance trap, developers can achieve power isolation between the two components through physical separation, such as placing the power amplifier at one corner of the board and the GNSS receiver at the other. This distance also reduces air- and board-radiated noise.

Power isolation can be extremely effective. For example, even on a board that is only  $2 \times 4$  centimeters, physi-

**The requirement of two TCXOs is one of the major barriers to introducing GNSS position tracking technology into cellular handsets. TCXOs are one of the most expensive components on the system bill of materials.**

cal separation can achieve isolation of between 10 and 25 dB (although 10 dB isolation is a widely accepted value).

**Sharing a System Oscillator – Not.** Perhaps the most common misconception, and the most difficult to recover from, is the belief that the existing cellular phone system oscillator will suffice for the GNSS system. For example, the receiver reference clock — normally a temperature compensated crystal oscillator (TCXO) or voltage controlled TCXO (VCTCXO) — in a GSM handset is typically accurate to 5–10 ppm. To realize specified GNSS (in particular GPS) sensitivity of less than -160 dBm, however, TCXO accuracy typically needs to be less than 0.5 ppm.

Part of the confusion arises from the fact that the RF radio itself isn't the only part of the GNSS receiver that relies on the stability of the receiver reference clock (TCXO). For example, the overall sensitivity of the GNSS receiver can be significantly improved through various correlation techniques. The longer the time over which the correlated GNSS signal is integrated, the more noise that can be removed.

Noise has a direct bearing on the resulting sensitivity and, until quite recently, coherent-integration in GPS was limited to 20 milliseconds (i.e., the period of the 50 bits per second GPS data

message). New techniques now allow for coherent integrations to occur over much longer periods, sometimes in excess of one second. However, if the receiver reference clock stability isn't high enough, the GNSS subsystem cannot reliably use these important, long coherent integrations to improve sensitivity.

On the other hand, product designers are prevented from using the more accurate reference clock required for GNSS processing to take care of other timing

needs in a multi-function mobile device. GSM systems, for instance, adjust the reference frequency based on feedback from the base station, which will be an issue for GPS.

A mobile GSM handset needs to perform Doppler compensation, and many implementations do so using a digital/analog converter that drives a control voltage into a VCTCXO. The control of the VCTCXO in this case is periodic, not continuous; so, changes in VCTCXO frequency are often step changes. If the GNSS subsystem uses the same VCTCXO as the GSM system, these step changes in frequency would cause dramatic phase changes in the receiver clock and prevent the correlators in the GNSS system from keeping lock on satellite signals.

This same factor would also eliminate the possibility of using long coherent-integrations to achieve higher GNSS sensitivity. The use of a single TCXO would require a mechanism for notifying the GNSS subsystem of TCXO frequency changes in a timely fashion so as to compensate for them.

The requirement of two TCXOs is one of the major barriers to introducing GNSS position tracking technology into cellular handsets. TCXOs are one of the most expensive components on the system BoM, typically costing more

than \$1. Much work is being done to overcome this cost barrier.

**Avoiding Inaccurate Assumptions About Design**

Perhaps the best advice for designers new to RF technology is to remember that RF design requires sensitivity levels that are far more stringent than almost every other application.

An important step in maximizing RF and processing performance is to accurately evaluate and select the best components for a particular application. Once components have been selected for use in a design, it can be extremely difficult — and expensive — to change them out. From this perspective, many common design assumptions do not carry over to RF systems. For example, developers often make arbitrary reference-design adjustments, such as changing out components and moving sections around the printed circuit board to reduce system BoM.

In RF designs, radio sensitivity is crucial. To call sensitivity fickle would be an understatement. RF component companies offer reference designs because many nuances are difficult to capture in spec sheets or block diagrams. These reference designs typically don't have extra components; every component and trace has been carefully considered to take into account tolerances, avoid interference, and minimize board losses.

Before removing, changing, or modifying the placement of any components, a designer must understand the effect of the overall design and the relationship among the various components on signal sensitivity. This does not mean that reference designs don't have higher sensitivity requirements than a particular application might require. Rather, companies supply them so that developers new to RF design can avoid accidentally degrading signal sensitivity beyond recovery.

After successfully introducing GNSS technology to an architecture and gaining experience with RF, developers can then take on cost-reducing strategies with significantly less risk of forcing a redesign or delaying time to market.

**GNSS Sensitivity** continued on page 52

## Conclusion

Introducing position tracking using GNSS technology promises to transform the consumer electronics industry. By understanding that RF sensitivity is the key to accuracy, developers can avoid common design pitfalls that delay time to market and increase system cost. Additionally, by using the proper components and taking advantage of next-generation innovations such as software-based baseband processing, developers can achieve the best sensitivity and accuracy without having to become RF experts themselves.

## Authors



**Stefan Fulga**, director of strategic marketing for SiGe Semiconductor's strategic marketing activities in GNSS, WiFi and WiMAX segments, previously led the devel-

opment of the company's GNSS products as a director of engineering. He has been with SiGe Semiconductor for eight years, working on Bluetooth power amplifiers, cable telephony tuners, and GNSS products. Prior to that he worked at Nortel's semiconductor group as a mixed signal IC design engineer. Fulga holds a bachelor of electrical engineering degree from Concordia University in Montreal, Canada, and a PLD degree from Harvard Business School in Cambridge, Massachusetts, USA.



**Peter L. Gammel**, SiGe Semiconductor's chief technical officer and vice-president of Engineering, has worked with single-electron devices, superconducting devices, and MEMS and RF acoustic wave devices for more than 20 years. He is well acquainted with the processes of intellectual property investment and new product and funding development. Gammel previously served as VP engineering at a venture-backed startup, assembling and managing a 15-person team to develop RF acoustic wave products. He was CTO at both AdvanceNanotech, Inc. and

Agere Systems (analog products business unit), and was a research director at Bell Laboratories. He has more than 200 referred technical publications and more than 25 patents issued and in process. He holds a Ph.D. in physics from Cornell University and bachelor of science degrees in physics and mathematics from Massachusetts Institute of Technology (MIT).



**Malcolm Lomer** is product marketing manager, GNSS Solutions, for SiGe Semiconductors, having marketed GNSS products for six years. He has more than 15 years technical, sales, and marketing experience in the GPS market. In his current position, he is responsible for SiGe Semiconductor's GPS and GNSS RF front-end IC products. Prior to joining SiGe, Lomer worked at SiRF Technology as a field application engineer. Before that he held the position of market development manager for GPS at Zarlink Semiconductor. Lomer holds a bachelor of science degree in electronics from the University of Manchester's Institute of Science and Technology in the United Kingdom. 

# InsideGNSS