

GNSS Solutions:

WAAS Functions and Differential Biases

“GNSS Solutions” is a regular column featuring questions and answers about technical aspects of GNSS. Readers are invited to send their questions to the columnists, Professor Gérard Lachapelle and Dr. Mark Petovello, Department of Geomatics Engineering, University of Calgary, who will find experts to answer them. Their e-mail addresses can be found with their biographies at the conclusion of the column.

Do GNSS augmentation systems certified for aviation use, such as the GPS Wide Area Augmentation System (WAAS), have a function other than improving the accuracy of user navigation?

The short answer is yes. The principal function of GNSS augmentation systems designed for aviation is to provide users with a “certificate” of safety evaluated in real-time. This certificate guarantees that users are extremely unlikely to suffer a large positioning error that might lead to a hazardous situation (such as a collision or a botched landing).

Functionally, GNSS augmentation systems broadcast differential corrections that *do* improve user positioning accuracy. Broadcast messages also report error bounds for individual GNSS satellites and warnings of rare system faults or atmospheric anomalies. By integrating all these components of the broadcast message, users can validate that their navigation systems will support safety critical operations.

Before explaining the nature of this safety certificate, let’s first review the major classifications of GNSS augmentation systems

under development by the aviation community. These are generally classified as either space-based augmentation systems (SBAS) or ground-based augmentation systems (GBAS).

In SBAS, messages are broadcast over large areas (thousands of kilometers across) through one or more communication satellites located in geosynchronous Earth orbit. In contrast, GBAS messages are broadcast in a local area (tens of kilometers across) via a terrestrial VHF antenna. Each class of augmentation offers distinct advantages, with space-based services reaching more users and ground-based services enabling more accurate differential corrections and quicker message transmission times.

Commissioned in 2003 for instrument flight use, the Federal Aviation Administration’s (FAA’s) WAAS became the first operational SBAS, providing service to users across North America. Other SBAS services are under development worldwide, including EGNOS in Europe, GAGAN in India, and MSAS in Japan. GBAS services are also under development. Notably, the FAA and Air Services Australia are coordinating to certify the Local Area Augmentation System (LAAS), an airport-based GBAS designed to support automated landing.

Fundamentally, both types of augmentation system supplement GNSS with an additional data broadcast. To generate a certificate of safety these data broadcasts provide users with three types of information: differential corrections for individual satellites, error bounds for those differential corrections, and (on rare occasions) messages alerting users of a suspected satellite fault.

Augmentation systems generate differential corrections using reference stations at known locations. When applied by users, these corrections significantly reduce GNSS positioning errors introduced by satellite clock

drift and by atmospheric delays. WAAS users, for instance, experience typical positioning errors of two meters (95 percent) in comparison with users of unaided GPS, who experience typical errors of eight meters or more (95 percent).

Some residual errors remain after the application of differential corrections; so, augmentation systems also broadcast “sigma” error bounds for each satellite. Error bounds are broadcast for individual satellites (rather than for the position solution) so that users may customize their error bounds to reflect the particular combination of GNSS satellites they have in view.

The user receiver constructs a bound on position error by combining the satellite error bounds under the assumption that they represent independent Gaussian distributions with standard deviations equal to the broadcast “sigma” levels. Because these assumptions are not precisely true, augmentation systems must broadcast sigma values somewhat larger than the nominal values computed from sampled data. This process is commonly referred to as “sigma inflation.”

As an example, a user would employ the following equation to construct a conservative estimate of the vertical positioning error (σ_v) from the inflated error levels (σ_i) associated with a number (N) of satellites in view and their associated contributions (s_i) to the weighted least-squares position solution.

$$\sigma_v = \sqrt{\sum_{i=1}^N (s_i \sigma_i)^2}$$

Even under nominal conditions, random errors may occasionally take on values much larger than the broadcast sigma levels. To account for these infrequent events, users generate a *protection level*, a bound on all but the rarest user errors. (In the terminology of statistics, protection levels might also be called *confidence intervals*.)

Unfortunately, it is not generally possible to define a meaningful bound for all errors because, in theory, errors could reach magnitudes of thousands of kilometers or more. Accordingly, certification authorities have carefully specified the allowed risk that the navigation system error may exceed the protection level.

For safety-critical applications, risk tolerance is extremely small. Errors may exceed the protection level only one time in ten million aircraft approaches. Based on this requirement, an expression for protection level can be derived from the broadcast sigma values. The vertical protection level (*VPL*), for instance, is related to the vertical sigma level (σ_v) by a proportionality factor K .

$$VPL = K\sigma_v$$

Given that actual user navigation errors are always unknown, users may nonetheless obtain a certificate of

Inside GNSS

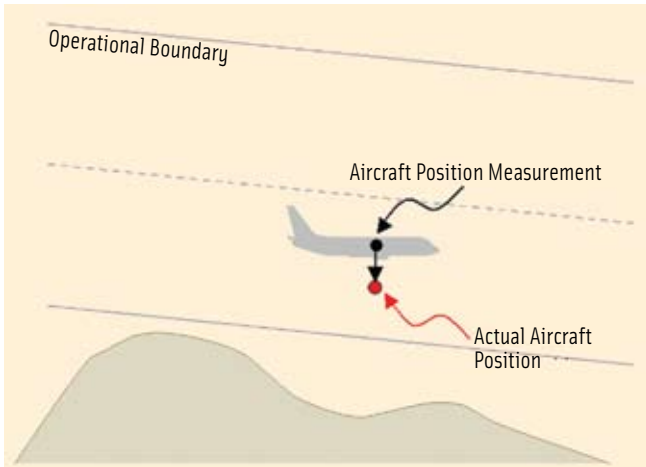

FIGURE 1 Residual navigation errors are unobservable

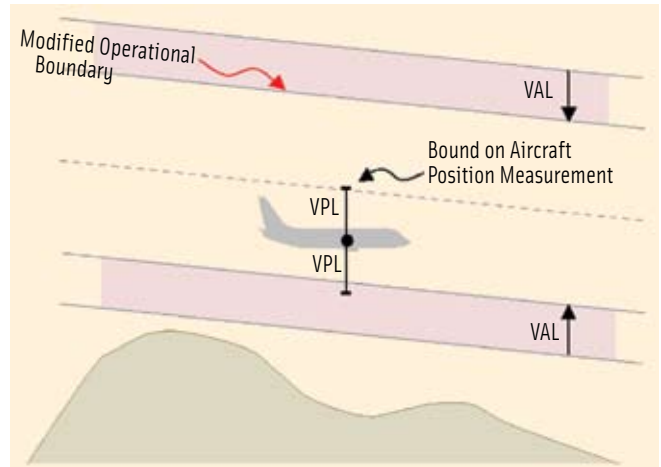

FIGURE 2 The aircraft may safely fly in a modified operational corridor if $VPL < VAL$

safety as long as their protection levels remain below a hazardous level. In practice, the protection level is compared to an alert limit, which signifies the smallest error that is hazardous for a particular type of operation.

For example, WAAS users attempting an approach that meets the standard for localizer performance with vertical guidance (LPV) 200, which requires pilot visibility below a 200-foot ceiling, must satisfy an alert limit of 35 meters in the vertical direction. WAAS users attempting a less restrictive, conventional LPV approach, which requires greater pilot visibility (below a 250 foot ceiling), need only satisfy an alert limit of 50 meters in the vertical.

Considering only the vertical direction (which is generally more restrictive than the horizontal), a certificate of safety is established if a user's VPL is smaller than the Vertical Alert Limit (VAL):

$$VPL \leq VAL$$

In essence, this certificate allows users to operate safely within a modified flight corridor (reduced in dimension by the VAL) without concern about the unknown size of the instantaneous navigation error, as illustrated in **Figures 1 and 2**.

One of the most challenging aspects in developing an augmentation system is determining inflated error levels

(σ_v) that are small enough to support tight alert limits but that nonetheless are large enough to ensure the validity of the protection level (given that actual error distributions are neither independent nor Gaussian, as assumed by the user).

Another challenge in designing augmentation systems is protecting users from rare system faults and atmospheric anomalies. Although GNSS systems are highly reliable, faults do occur.

Examples of GPS faults that have been observed in its last two decades of operation include satellite clock failures, anomalous deformation of the GPS code signal, and faulty ephemeris data broadcasts. Any of these failures may result in GPS positioning errors of tens or hundreds of meters, even for users applying differential corrections. Severe ionosphere storms may also degrade differential corrections and, in extreme cases, result in errors of tens or hundreds of meters.

To maintain valid protection levels, augmentation systems monitor individual GNSS signals and flag unusual behavior. In order to obtain a certificate of safety, users must not use these suspicious satellites in computing their GNSS position solutions. The certificate depends on rapid transmission of warning flags.

Currently, the operational control segment for GPS has the ability to flag

individual satellites as unhealthy, but generally responds to problems only hours after they have occurred. By contrast, the monitors incorporated in WAAS are designed to support precision approach by identifying satellite or atmospheric anomalies within 6.2 seconds after the user error becomes hazardous (meaning that the error exceeds the protection level).

Examples of WAAS monitors include a code-carrier coherence monitor (which checks for divergence of the timing references for code and carrier measurements), a signal deformation monitor (which checks correlator peak shape to identify ringing or delays in the code bit transitions), and an extreme storm detector monitor (which identifies regions of possible ionosphere storm activity by assessing the planarity of ionosphere delays across North America). The demands for precision landing are even more stringent; so, LAAS is designed to support an alert time of less than 2 seconds.

Monitors do have a downside. Accidental exclusion of healthy satellites can decrease the number of satellites in view, making the least-squares solution less accurate and the vertical positioning error (σ_v) higher. If the increased vertical positioning error causes VPL to exceed VAL, the false alarm causes the system to become unavailable.

These availability breaks are highly undesirable, particularly as a poorly timed false alarm may result in a balked landing. Balancing monitor response time and sensitivity to avoid false alarms introduces a significant challenge in the development and certification of augmentation systems for aviation.

In summary, the primary mission for aviation augmentation systems is to guarantee bounded-error navigation for safety critical applications. Aviation augmentation systems have

taken much longer to develop than conventional differential correction systems, in large part because of the difficulties in rigorously validating their safety requirements.

JASON RIFE



JASON RIFE is an assistant professor of mechanical engineering at Tufts University in Medford, Massachusetts, USA. He received his Ph.D. in mechanical engineering

from Stanford University in 2004. Before joining the faculty at Tufts, he served as a research associate in the Stanford GPS lab where he participated in development of the Local Area Augmentation System (LAAS) and the Joint Precision Approach and Landing System (JPALS). His current research focuses on robotics and navigation.

What are WAAS GEOs' L1 and L5 Differential Biases and How Are They Estimated?

Presently, the Federal Aviation Administration (FAA) space-based augmentation system (SBAS), known as the Wide Area Augmentation System (WAAS), uses geostationary earth orbit (GEO) satellites to broadcast corrections and integrity information to users.

A secondary use of the GEO signal is to provide users with a GPS-like ranging source. As of July 2007, the FAA started using two new GEOs with pseudorandom noise (PRN) designations 135 and 138 to provide this information. These new GEOs have L1 and L5 downlink frequencies.

Historically, the GEO communication and control segment (GCCS) ranging signal has been generated on the ground and provided via C-band uplink to the GEO, where the navigation payload translates the uplinked signal to an L1 downlink frequency. For the new

GEO satellites, an additional C-band uplink is converted to the L5 downlink frequency. When both the L1 and L5 downlink signals are received at the GEO uplink ground station, they are used to provide ionospheric delay observations.

A key feature of GCCS is the addition of a second independently generated and controlled uplink signal. Therefore, GCCS uplinks two independent C-band signals that are translated to L1 and L5 downlink signals.

Closed loop control of the GEOs' L1 and L5 broadcast signals in space (SIS) is necessary to ensure that the algorithms compensate for various sources of uplink divergence between the code and carrier, including uplink ionospheric delay, uplink Doppler, and divergence due to carrier frequency translation errors induced by the GEOs' transponder. Use of two independent broadcast signals creates a unique challenge in estimating biases and maintaining coherency between the two signals.

A control loop functional block diagram for GEO/GCCS system is shown in Figure 1. Each of the L1 and L5 control loops consists of an ionospheric delay estimation Kalman filter, a range Kalman filter, a code control function and a frequency control function.

In addition, an L1 and L5

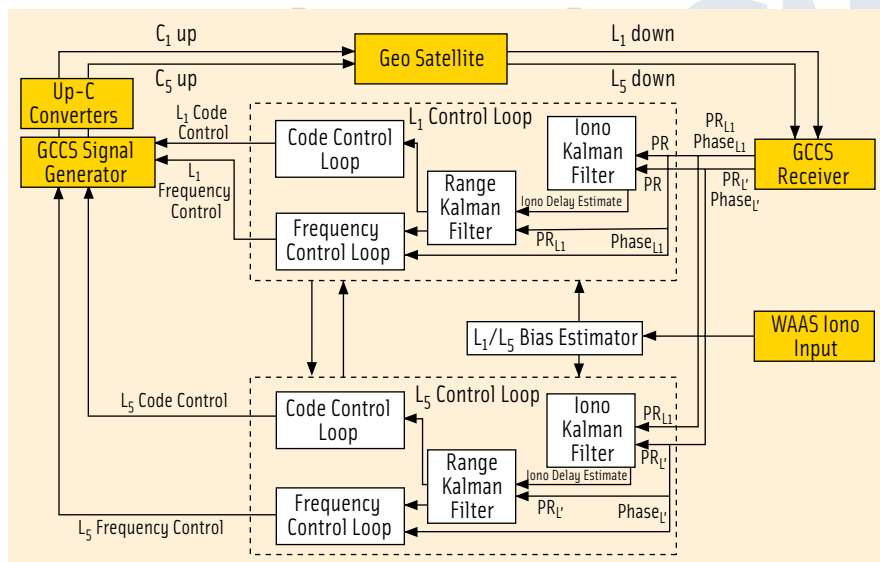

FIGURE 1 Control loop functional block diagram of GCCS

differential bias estimation function estimates the bias between the L1 and L5 that is due to differential measurement errors in the predetermined hardware delays of the two signal paths. If not estimated and compensated, the bias between L1 and L5 will be indistinguishable from ionospheric delay, as shown in the equations below.

L1 and L5 pseudoranges can be expressed as

$$PR_{L1} = R + I_{L1} + \text{true } d_{L1} + \text{clock error} + \text{tropo delay}, \quad (1)$$

$$PR_{L5} = R + I_{L5} + \text{true } d_{L5} + \text{clock error} + \text{tropo delay}, \quad (2)$$

where R is the true range, I_{L1} is the true L1 iono delay, I_{L5} is the true L5 iono delay, true d_{L1} is the true L1 downlink path hardware delay, and true d_{L5} is the true L5 downlink path hardware delay.

At the ground control station, this becomes

$$PR_{L1} - d_{L1} = R + I_{L1} + \text{true } d_{L1} + \text{clock error} + \text{tropo delay} - d_{L1}, \quad (3)$$

$$PR_{L5} - d_{L5} = R + I_{L5} + \text{true } d_{L5} + \text{clock error} + \text{tropo delay} - d_{L5}, \quad (4)$$

where d_{L1} is the predetermined (measured) L1 downlink path hardware delay and d_{L5} is the predetermined (measured) L5 downlink path hardware delay.

Let $\Delta d_{L1} = \text{true } \Delta d_{L1} - \Delta d_{L1}$ and $\Delta d_{L5} = \text{true } \Delta d_{L5} - \Delta d_{L5}$. By subtracting Equation 4 from Equation 3, the measurements for the L1 ionospheric delay Kalman filter become

$$z = \frac{(PR_{L1} - d_{L1}) - (PR_{L5} - d_{L5})}{1 - (L_1 \text{ freq})^2 / (L_5 \text{ freq})^2} \quad (5)$$

Rearranging Equation 5,

$$z = I_{L1} + \frac{(\Delta d_{L1} - \Delta d_{L5})}{1 - (L_1 \text{ freq})^2 / (L_5 \text{ freq})^2} \quad (6)$$

The second term in Equation 6 is the differential L1 and L5 bias term, and it becomes an error in the L1 ionospheric delay estimation. The L5 ionospheric delay Kalman filter is similarly affected by the L1 and L5 bias term. The measurements for the L5 ionospheric delay Kalman filter become

$$z = I_{L5} + \frac{(\Delta d_{L1} - \Delta d_{L5})}{(L_5 \text{ freq})^2 / (L_1 \text{ freq})^2 - 1} \quad (7)$$

WAAS L1 ionospheric delay is calculated by using the L1 ionospheric grid points' delays broadcast by the WAAS messages. This WAAS ionospheric delay is compared with Equation 6. The differential between the two ionospheric calculations gives the differential bias between L1 and L5.

The term

$$\frac{(\Delta d_{L1} - \Delta d_{L5})}{1 - (L_1 \text{ freq})^2 / (L_5 \text{ freq})^2}$$

is calculated by using the WAAS ionospheric delay as an input shown in Figure 1. This will be compensated in both L1

and L5 ionospheric delay Kalman filters. When the GPS IIF or GPS III constellation is achieved, the L1 and L5 differential will be estimated by SBAS (WAAS) as it is done now with L1 and L2 differential bias estimation.

Additional Resources

[1] Grewal, M., and L. Weill and A. Andrews, *Global Positioning Systems, Inertial Navigation, & Integration, Second Edition*, Wiley & Sons, 2007

[2] Grewal, M., and A. Andrews, *Kalman Filtering Theory & Practice Using MATLAB, Second Edition*, Wiley & Sons, 2001

[3] Grewal, M., with P. Hsu and L. Cheung. "Prototype Test Results of L1/L5 Signals of Future GEO Satellites," ION GNSS 2004 Conference, September 21-24, 2004, Long Beach California, USA

[4] "Method and Apparatus for Wide Area Augmentation System Having L1/L5 Bias Estimation." Publication No. WO/2007/037957, Publication Date 5.04.07

MOHINDER S. GREWAL



MOHINDER S. GREWAL, Ph.D., P.E., is professor of electrical engineering at California State University, Fullerton. He is an architect of the GEO Uplink Subsystem (GUS) for WAAS, including the GUS clock steering algorithms. E-mail: <mgrewal@fullerton.edu>.



Mark Petovello is an assistant professor in the Department of Geomatics Engineering at the University of Calgary. He has been actively involved in many aspects of positioning and navigation since 1997 including GNSS algorithm development, inertial navigation, sensor integration, and software development.

Email: <mark.petovello@ucalgary.ca>



Professor Gérard Lachapelle holds a CRC/iCORE Chair in Wireless Location in the Department of Geomatics Engineering at the University of Calgary. He has been involved with GNSS since 1980 and has received numerous awards for his contributions in the area of differential kinematic GPS and indoor location.

Email: <gerard.lachapelle@ucalgary.ca>