

GNSS Solutions:

Weighting GNSS Observations and Variations of GNSS/INS Integration

“GNSS Solutions” is a regular column featuring questions and answers about technical aspects of GNSS. Readers are invited to send questions to the columnists, Professor Gérard Lachapelle and Dr. Mark Petovello, Department of Geomatics Engineering, University of Calgary, who will find experts to answer them. Their e-mail addresses can be found with their biographies at the conclusion of the column

How important is GNSS observation weighting?

In the early days of GPS, most receivers tracked only as many satellites as were required to compute a position. This meant that observation weighting was not needed and not even possible when processing on the epoch-by-epoch level. Soon, though, receivers were capable of tracking all satellites “in view,” and instead of the four minimum pseudorange observations required for a three-dimensional position, five, six, or more pseudoranges could be available at each epoch. GNSS observation redundancy will increase further as GLONASS and Galileo approach their full constellations.

Inevitably, redundant observations are inconsistent. At first sight, this might seem a nuisance best avoided by selecting a suitable non-redundant subset of the observations to compute position and receiver clock bias — for example, the one yielding minimum GDOP. In reality, however, GDOP tells nothing about the actual errors of the observations, and the chosen subset may produce a larger position error than other subsets would. It is far better to exploit the inconsistencies using statistical methods such as least-squares (LS) estimation, Kalman filtering, and hypothesis testing. This increases the positioning precision, allows checking for failures, and reduces the probability of undetected gross errors.

However, exploiting the inconsistencies requires that the relative precision of each observation with respect to the other observations be known.

A precise observation should have a higher weight and thus contribute more to the computed parameters than an imprecise one. Proper observation weighting is only possible if the variance-covariance matrix (VCM) of the observations is known, and in fact LS estimation and Kalman filtering yield the most precise results only if the correct VCM is used (advanced approaches with less stringent requirements are beyond the scope of this column).

Knowledge of the VCM is even more important in view of statistical failure detection and identification; inappropriate weights may cause outliers to remain undetected and truly accurate observations to be rejected, thus inverting the desired benefit of quality control into a considerable loss of accuracy. Both redundant observations *and* proper observation weighting are essential for obtaining a precise and reliable estimate.

Proper observation weighting, as it turns out, is not a trivial task with GNSS observations. The reason is that the variance must incorporate all unmodeled effects and thus depends on factors such as tracking loop characteristics, receiver and antenna hardware, signal strength, receiver dynamics, multipath effects, atmospheric propagation effects, and so forth, most of which can hardly be controlled or determined accurately. The practical solution is to use a simple variance model that comes close enough to reality so that LS estimation or Kalman filtering yield nearly optimum results and reliability checking works well.

The simplest variance model assigns identical variance to all observables of the same type produced by the same receiver, for example, 1m^2 for C/A pseudorange, 1 Hz^2 for L1 Doppler, and 0.01^2 cyc^2 for L1 carrier phase. Several studies have shown that this is not a suitable variance model, unless the receiver is operated only in clear-sky environment under line-of-sight conditions, and only high elevation satellites are used. Elevation or C/N_0 (carrier-to-noise-density ratio) dependent

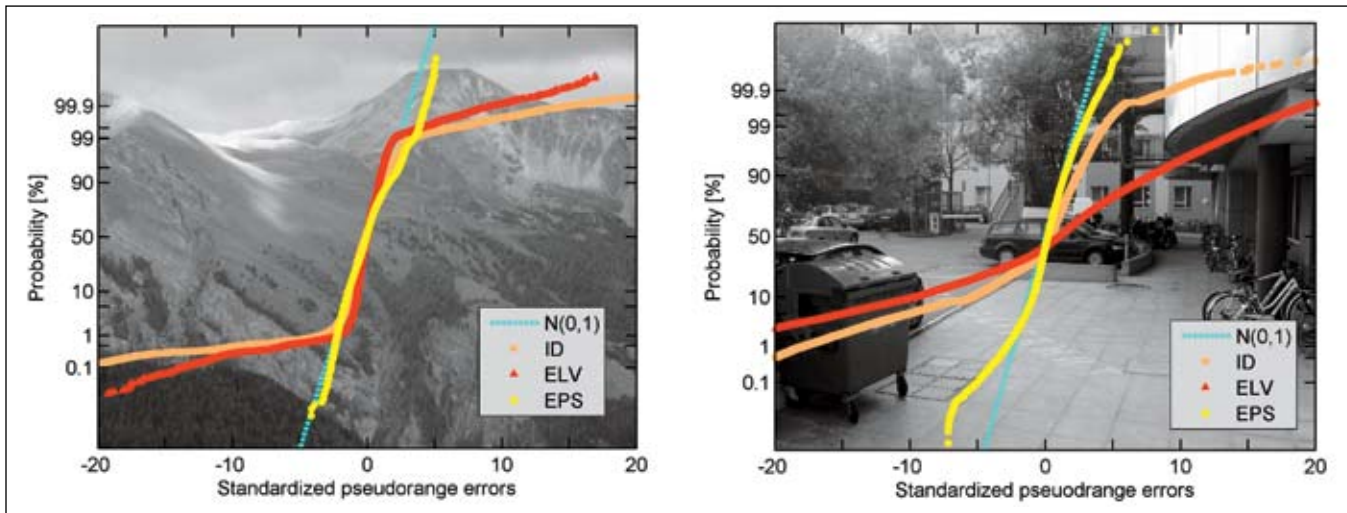

FIGURE 1 Normal probability plot of standardized pseudorange errors from low-multipath dataset (left) and high-multipath data set (right)

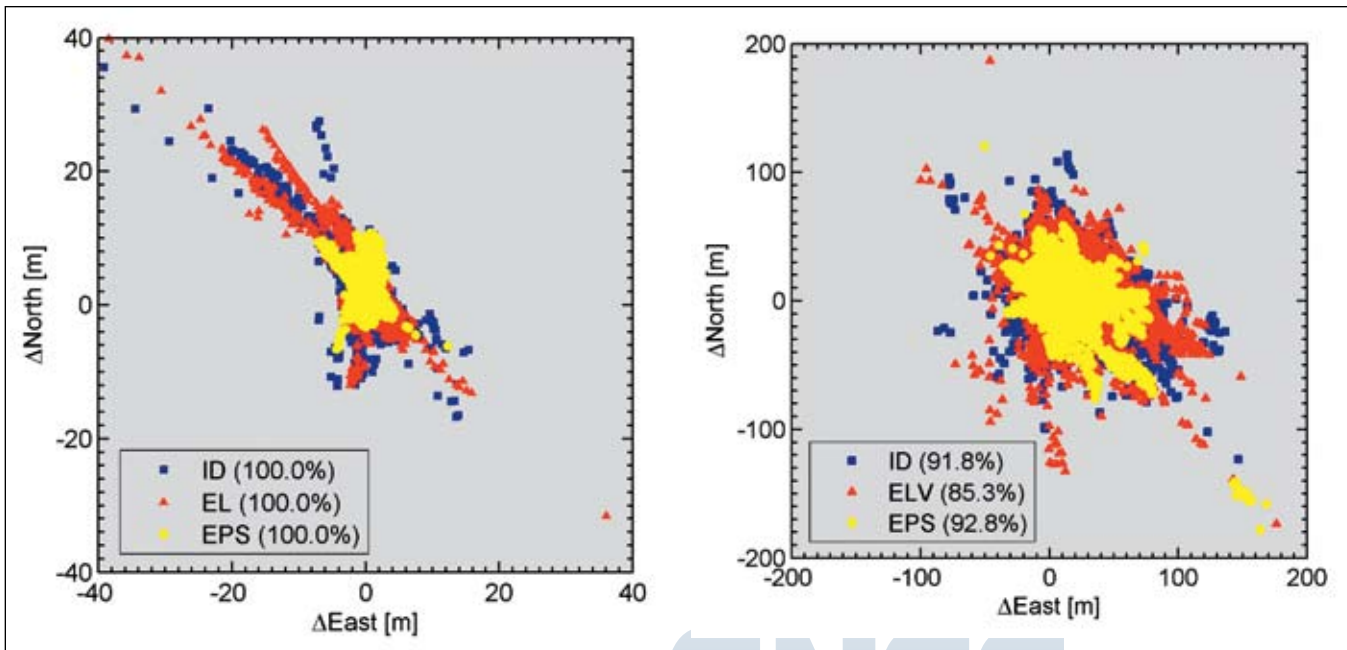

FIGURE 2 Error of estimated receiver positions in a low-multipath environment (left) and high-multipath environment (right; note different scale of axes). Percentages of solutions with more than four satellites are shown in brackets in the legend.

variance models usually perform significantly better, with the C/N_0 -based models being more widely applicable. This can be shown both in the observation domain (Figure 1) and in the coordinate domain (Figure 2).

Figure 1 presents a so-called normal probability plot of pseudorange errors obtained from two different static GPS data sets: a three-hour low-multipath data set collected on a mountain slope (left) and a five-hour

high-multipath data set collected in a dense urban environment (right).

The coordinates of both locations were precisely known beforehand; so, 'pseudorange errors' could be estimated. These errors were then standardized using three different variance models: (i) identical variances σ^2 (ID), (ii) elevation dependent variances $\sigma_0^2 / \sin^2 E$ (ELV), and (iii) SIGMA- ϵ variances $C^2 \cdot 10^{-C/N_0/10}$ (EPS). The model parameters σ , σ_0 , and C depend on the

receiver and antenna types, and were determined in advance.

If the observations are normally distributed and their variance is matched by any of the variance models, the corresponding standardized errors should lie exactly on the blue straight line in Figure 1. Actually, all three models represent the majority of the low-multipath data set well (left), with a slight advantage shown for EPS (see vertical axis range over which the

plotted data coincide approximately with the straight line). However, both ID and ELV fail completely in the high-multipath environment (right), while EPS still represents more than 90 percent of the data.

Figure 2 shows that, indeed, the precision of the computed coordinates depends on the chosen variance model. The plot on the left contains the epoch-by-epoch results obtained from the low-multipath data set at the mountain slope. The identical raw observations were processed separately using each of the three variance models. Obviously, EPS yields the highest precision and the fewest large errors.

The plot on the right contains the corresponding position solutions obtained for the high-multipath site, and again EPS yields the best results: 95% of the position errors are within 38 meters, as opposed to 60 meters when using the other variance models. Furthermore, fewer observations are rejected as potential outliers by the quality control kernel when using EPS, and thus the percentage of epochs with a controlled solution based on more than four pseudorange observations (see numbers in legend) is higher. Similar patterns can also be found with Doppler processing and with carrier phase processing, where a proper vari-

ance model is also crucial for successful ambiguity resolution.

The above examples highlight the fact that proper GNSS observation weighting is in fact very important in order to obtain the most precise and reliable position, velocity, and time solutions that can be computed from a given set of redundant observations.

ANDREAS WIESER

Dr. Andreas Wieser is a university assistant with the Institut für Ingenieurgeodäsie und Messsysteme at the Graz University of Technology. He has worked on GNSS weight models and quality control as part of his Ph.D. dissertation, and he has been actively involved in parameter estimation and GNSS research since 1998.

Editor's Note For details of observation weighting models, see the following references:

Collins, J.P., and R.B Langley, "Possible Weighting Schemes for GPS Carrier Phase Observations in the Presence of Multipath," Geodetic Research Laboratory, University of New Brunswick, Canada, Report to the United States Army Corps of Engineers Topographic Engineering Center, <<http://gauss.gge.umb.ca/papers.pdf/acereport99.pdf>>, (1999)

Euler, H.J., and C. C. Goad, "On optimal filtering of GPS dual frequency observations without using orbit information," *Bulletin Géodésique* 65: 130-143 (1991)

Hartinger, H., and F. K. Brunner, "Variances of GPS Phase Observations: the SIGMA- Model," *GPS Solutions* 2/4: 35-43, (1999)

Wieser, A., and M. Gaggl and H. Hartinger, "Improved positioning accuracy with high-sensitivity GNSS receivers and SNR aided integrity monitoring of pseudo-range observations," in *Proceedings ION GNSS 2005*, 18th Int. Technical Meeting of the Satellite Division, Sept. 13-16, Long Beach, CA: 1545 - 1554, (2005)

Wieser, A., "Robust and fuzzy techniques for parameter estimation and quality assessment in GPS," Ph.D. dissertation, Graz University of Technology, Shaker Verlag, Aachen, ISBN 3826598075 (2002)

"What is the difference between 'loose', 'tight', 'ultra-tight' and 'deep' integration strategies for INS and GNSS?"

The terms *loose*, *tight*, *ultra-tight*, and *deep* are used to describe the way in which information from an inertial navigation system (INS) and a GNSS receiver are fused in an integrated navigation system. More than a decade ago, R. L.

InsideGNSS
GPS | GALILEO | GLONASS

Greenspan in his seminal work on INS/GPS integration (see citation in Further Readings section at the end of this Solution.) described the “loose” and “tight” integration architectures in the way they were understood at the time.

Over the years, however, a slight departure from these definitions has occurred. Unfortunately, this has led to some confusion especially because — as a review of recent literature on the subject indicates — an alternate consensus has emerged regarding the terms used to describe the various INS/GNSS architectures. Another source of confusion is the fact that some INS/GNSS architectures contain elements of the various fusion schemes such that they cannot be described simply as loose, tight, or deep.

In the following discussion, we present a synopsis of the various INS/GNSS fusion architectures and point out where some of the confusion lies. (This discussion is *not* meant to be a tutorial on the details of INS/GNSS integration. The reader interested in a more detailed treatment of the subject is urged to consult the papers and texts listed in the “Further Reading” section at the end of this article.)

Before we discuss the definitions of these terms and architectures, however, it would be beneficial to define some terminology and review the overall objectives of INS/GNSS fusion.

Overview of INS/GNSS Fusion. An INS is a self-contained navigator that generates an attitude (orientation), position, and velocity solution at rates higher than those normally available from a GNSS receiver. The sensors used in an INS are a triad of gyros (for measuring rotation or rotation rate) and accelerometers (for measuring accelerations or specific force). An INS is the combination of these sensors, navigation algorithms, and the computer which hosts the algorithms.

The INS algorithms for generating attitude, position, and velocity involve, in part, performing the mathematical operation of integration on the outputs of these sensors. Thus, any error on the output of the sensors leads to correlated attitude, position, and velocity errors that are potentially unbounded.

A GNSS receiver, on the other hand, generates position and velocity estimates with bounded errors. Although GNSS can be used to provide an attitude solution, this is normally avoided in practice because it involves using a complex, and potentially costly, system with multiple receivers and antennas.

The error characteristics of an INS and GNSS are complementary. When the information from INS and GNSS are fused, the high-fidelity GNSS position and velocity estimates are used to calibrate the INS sensor errors. The INS, in turn, provides the high bandwidth attitude, position, and velocity estimates needed for vehicle guidance and control.

The INS estimates also allow coasting through momentary drop-outs of the GNSS solution, which can result from signal blockage caused by obstructions between the GNSS antennas and the satellites. Yet another way the INS informa-

Inside GNSS
GPS | GALILEO | GLONASS

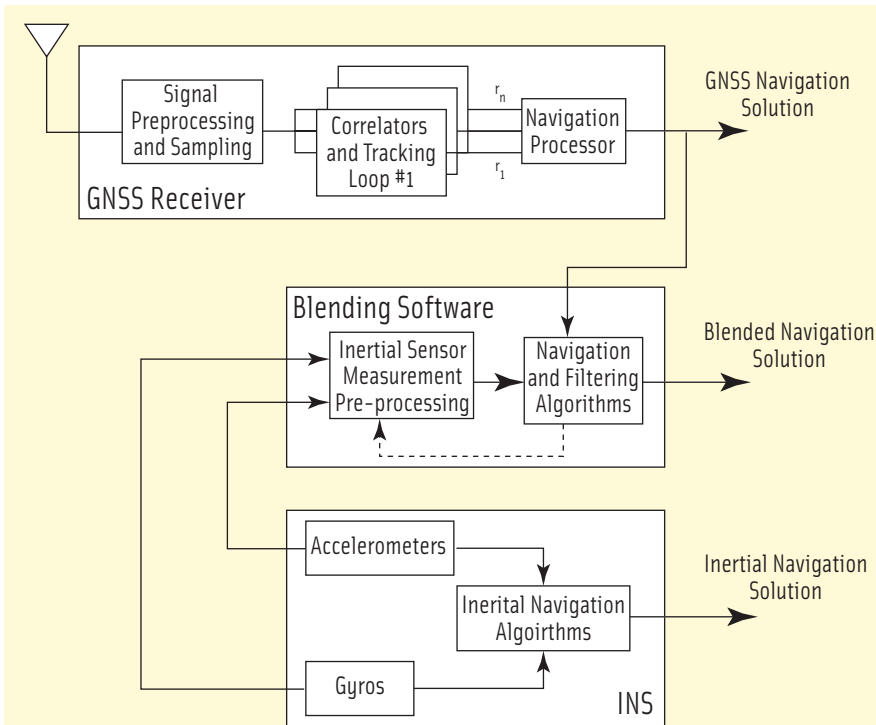

FIGURE 1 INS/GNSS Loose Integration

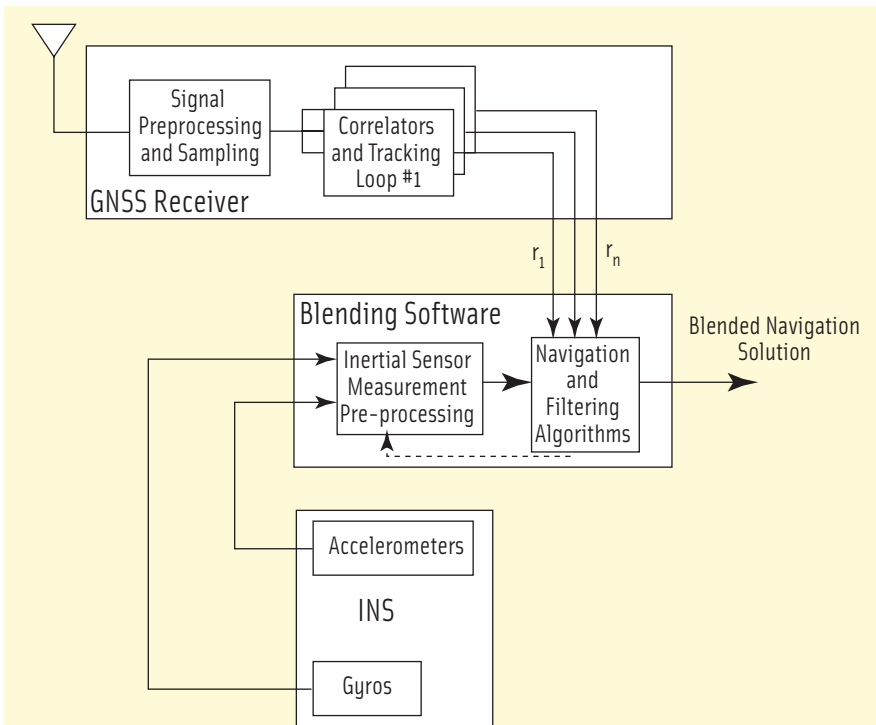

FIGURE 2 INS/GNSS Tight Integration (Classic Definition)

integration architecture. In the loose architecture, the INS and GNSS receivers operate as independent navigation systems. The information from them is blended using an estimator to form a third navigation solution. Normally, an extended kalman filter (EKF) is used to accomplish the blending even though currently some interest in using other non-linear estimators such as the unscented kalman filter or particle filters has arisen.

The purpose of the loose architecture is to extract the desirable attributes from INS and GNSS while suppressing the undesirable attributes of each. That is, the blended solution generated by loose integration of INS and GNSS features the high bandwidth information from the INS and the bounded errors from the GNSS.

There are many variants of the loose integration, and we will briefly describe a couple of examples here — what are sometimes referred to as *feedback* or *feed-forward* configurations. In the feedback configuration, inertial sensor errors estimated by the EKF are fed back to correct the rate gyro and accelerometer measurements. When the feedback path is absent, the configuration is said to be a *feed-forward* configuration.

The feedback path is shown by a dashed line in Figure 1 to indicate that it is not always required. When low quality inertial sensors (which have large output errors) are used, a feedback path is almost always required. In these instances, if the feedback path is absent, the linearization assumption inherent in estimators such as the EKF can be violated, leading to filter divergence.

The feed-forward configuration is normally used with high-grade inertial navigation systems, such as those found on commercial transport aircraft.

In summary, note that the key feature of loose integration is that both the INS and GNSS receiver are independent navigators. The information from the two navigators is blended to form a third navigation solution.

tion can be used is to help increase the robustness of GNSS receivers to jamming or radio frequency interference (RFI). This involves using INS infor-

mation to aid the signal processing algorithms inside a GNSS receiver.

Loose INS/GNSS Integration. Figure 1 shows a schematic of a loose INS/GNSS

Tight INS/GNSS Integration: Classic Definition. Tight INS/GNSS architecture, as defined by Greenspan (i.e., the classic definition), is illustrated in **Figure 2**. In this architecture, the INS and GNSS are reduced to their basic sensor functions. That is, pseudorange, pseudorange rate, accelerations, and gyro measurements are used to generate a single blended navigation solution.

In general, the classical tight architecture provides a more accurate solution than loose integration. Another advantage it has over the loose integration scheme is that tight integration can continue to extract useful information from a GNSS receiver in situations where fewer than four satellites are visible. Loose integration, however, has the advantage of redundancy because the INS and GNSS receiver still produce independent navigation solutions.

Tight INS/GNSS Integration: Alternate Definition. An alternate definition of

the tight integration architecture currently in use is shown schematically in **Figure 3**. In addition to the fact that the INS and GNSS receivers are reduced to their basic sensor functions, information from the blending filter is fed back to the GNSS receiver to enhance its performance. Specifically, the velocity (and possibly acceleration) information from the blending filter (shown in red in Figure 3) is used to aid the code and carrier tracking loops in the GNSS receiver.

This allows the GNSS receiver to remain in lock (that is, continue to track the signal) in high-dynamic maneuvers, which would not be possible, or would at least be difficult, without the aiding information. Another benefit of tight integration is that it can be used to narrow the tracking loop bandwidths of the GNSS receiver, thereby reducing noise and increasing the system's robustness to wideband interference or jamming.

The performance enhancements offered by this alternative comes at a price. Compared to a loose or a classic tight integration architecture, this version of tight integration is more complex in that it requires incorporating information from the blending filter into the GNSS tracking loops. Furthermore, in this tight integration architecture the GNSS receiver is no longer independent from the INS; consequently, a faulty INS sensor can affect the blended solution which, in turn, will affect the GNSS receiver's performance.

Deep INS/GNSS Integration. In current usage, the term *deep* integration (or *ultra-tight*, which is a specific variant of deep integration) refers to the kind of architecture shown in **Figure 4**. Two important features distinguish this integration scheme from the others discussed so far. First, the architecture of the GNSS receiver is fundamentally different from that traditionally

InsideGNSS
GPS | GALILEO | GLONASS

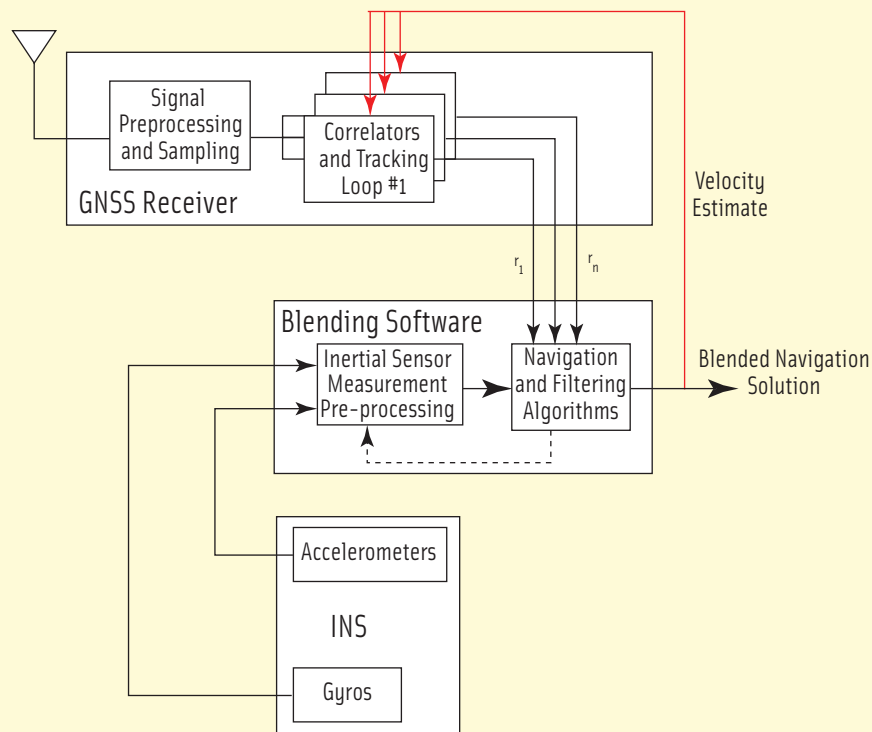

FIGURE 3 INS/GNSS Tight Integration (Alternate Definition)

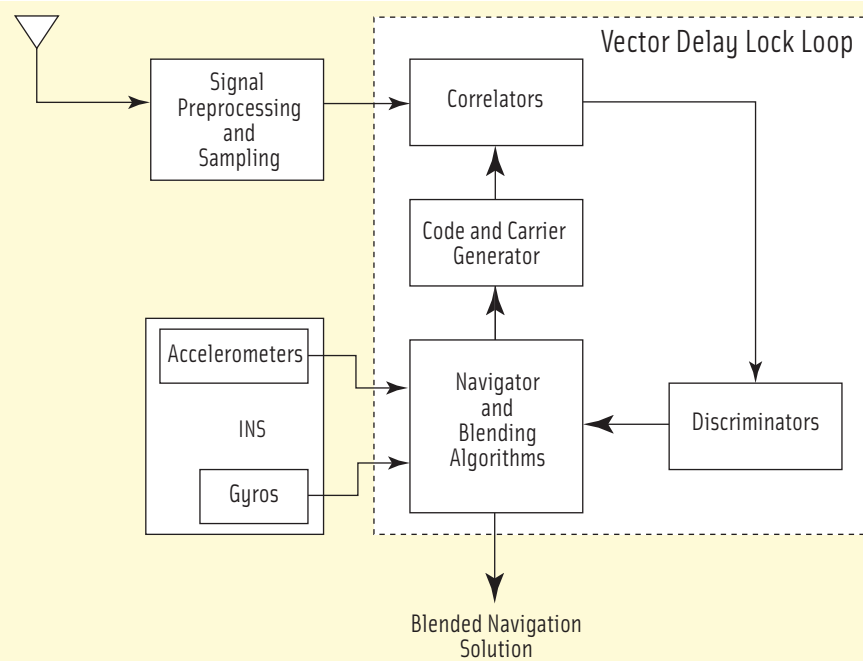

FIGURE 4 INS/GNSS Deep Integration

used in the loose and tight integration schemes. In this case, the traditional receiver architecture consisting of a bank of independent code and carrier tracking loops is replaced by something akin to a single vector delay lock loop (VDLL). The VDLL is enclosed in the dashed box shown in Figure 4.

The second distinguishing feature of deep integration arises from the use of the INS or information from the INS as an integral part of the GNSS receiver. That is, the GNSS receiver can no longer be viewed as a navigator independent of the INS. One of the many advantages of the deep integra-

tion architecture is that it enhances the robustness of GNSS to interference and jamming.

The enhancement afforded by this architecture exceeds that provided by tight integration. It also represents an optimal fusion of the information from an INS and a GNSS receiver. However, the major, readily apparent drawback of the deep integration scheme is the complexity involved in integrating INS information with GNSS information deep inside the receiver.

In summary, in going from the loose to the deep integration architectures, we gain robustness to GNSS outages either due to vehicle dynamics, interference, or jamming. However, this increased robustness comes at the sacrifice of system simplicity, redundancy, and independence of the INS and GNSS navigators.



Dr. Gebre-Egziabher is an assistant professor of aerospace engineering and mechanics at the University of Minnesota, in Minneapolis, Minnesota. His research is in the areas navigation, guidance and control with a particular emphasis on application of estimation theory to avionics sensor fusion and system integration issues.

Correction

Two recent *Inside GNSS* articles carried references to “Narrow Correlator,” which is a registered trademark of NovAtel, Inc., referring to the company’s patented technology. These articles were the GNSS Solution article on multipath mitigation technology in the October 2006 issue and “The Garda Project” article in the November/December issue. Use of this terminology should not have been made without reference to NovAtel and its trademark. The Garda Project article also includes a reference to “multi-correlator delay lock loop,” which should not be confused with NovAtel’s patented and trademarked Multipath Estimating Delay Lock Loop (MEDLL) technology. *Inside GNSS* regrets the oversight

Further Reading

For those interested the mechanics of INS/GNSS integration, the trade-offs involved in the various integration schemes, and the workings of advanced GNSS receiver designs such as the VDLL, a representative (but not exhaustive) list of references are given below.

INS/GNSS Integration:

Phillips, R., and G.T. Schmidt, "GPS/INS Integration," *AGARD Lecture Series on System Implications and Innovative Application of Satellite Navigation*, Paris, France, July 1996.

Cox, D. B., "Integration of GPS with Inertial Navigation Systems," reprinted in *Global Positioning System: Papers Published in NAVIGATION*, Institute of Navigation, Virginia, Vol. I, 1980, pp. 144–153.

Greenspan, R. L., "GPS and Inertial Integration," in *Global Positioning System: Theory and Applications*, Editors B. Parkinson, J. Spilker, P. Enge and P. Axelrad. AIAA, Washington, D.C., 1996, Vol. 2, pp. 187–220.

Benefits of INS-Aiding of GNSS Receivers

Pany, T., and R. Kaniuth and B. Eissfeller, "Deep Integration of Navigation Solution and Signal

Processing," *Proceedings of the ION-GNSS 18th International Technical Meeting*, Long Beach, California, September 2005, pp. 1095–1102.

Gebre-Egziabher, D., and A. Ravzi, P. Enge, J. Gautier, S. Pullen, B. Pervan, and D. Akos, "Sensitivity and Performance Analysis of Doppler-Aided GPS Carrier Tracking Loops", *Navigation*, Vol. 52, No. 2, 2005, pp. 49–60.

Vector Delay Lock Loops

Spilker, J., "Fundamentals of Signal Tracking Theory," in *Global Positioning System: Theory*

and Applications, Editors Parkinson, Spilker, Enge, and Axelrad. AIAA, Washington, D.C., 1996. Vol. 1. pp. 245–328.

Pany, T., and B. Eissfeller, "Use of Vector Delay Lock Loop Receiver for GNSS Signal Power Analysis in Bad Signal Conditions," *Proceedings of the IEEE-ION Position, Location and Navigation Symposium (PLANS) 2006*, San Diego, California, 2006. 

DEMOZ GEBRE-EGZIABHER



Mark Petovello is a Senior Research Engineer in the Department of Geomatics Engineering at the University of Calgary. He has been actively involved in many aspects of positioning and navigation since 1997 including GNSS algorithm development, inertial navigation, sensor integration, and software development.

Email: mpetovello@geomatics.ucalgary.ca



Professor Gérard Lachapelle holds a CRC/iCORE Chair in Wireless Location in the Department of Geomatics Engineering at the University of Calgary. He has been involved with GNSS since 1980 and has received numerous awards for his contributions in the area of differential kinematic GPS and indoor location.

Email: lachapel@geomatics.ucalgary.ca

InsideGNSS

GPS | GALILEO | GLONASS